



A New Angle



Tournament Info for “Structure” Team Managers



Paperwork

- **Go to the “CHECKER” table in morning**
 - Go over forms to make sure you have them all
- **Forms**
 - Tournament Data Form (5 copies)
 - Declaration of Independence (2 copies)
 - Expense Report Form (1)
 - Any Team Clarification Forms
- **Team Identification Sign (NOT scored)**
 - Just to let everyone know who you are
- **Get Tournament schedule**
 - Find out Instant Challenge (IC), Check-In, and Performance times and plan accordingly

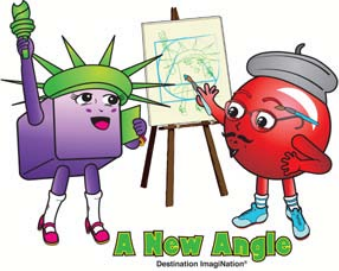

Check-In Procedure

- **Each team has scheduled Check-in, Perform. & IC times**
- **Usually Check-in will be in morning, Performance in afternoon**
 - Teams will be scheduled in same order as Performances
- **Teams will be in Check-in for about 10-15 min.**
 - Weighing and qualifying weight-bearing wood and glue structures
 - Discussions with appraisers about building experience
 - Wood structures will be kept for safe-keeping, told when to pick up for performance (please bring appropriate container)

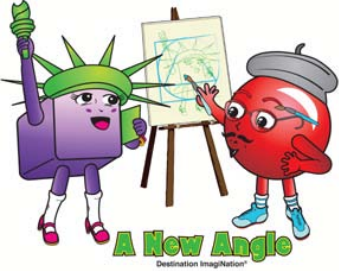

Check-in Room



- **Focus on team members**
- **Only team members handle structures**
- **Wood structure is weighed (both parts)**
 - Total structure weight ≤ 30.0 grams (Reg), 25.0 grams (Aff), 20.0 grams (GF)
- **Appraiser will then check:**

- Each structure part's height ≥ 3.75 inches
 - Each structure part meets required measurements for large & small ends
- The team will then assemble structure*
- Structure passes over **2** inch column
 - Structure fits onto tester base
 - **7 1/2"** \leq structure height above tester surface \leq **9"**
 - Any wood allowed as long as it is just natural wood (no plywood, laminates, composites, coatings)
 - Glue may only be used as an adhesive
 - Glue may not extend beyond **1/4"** of a joint

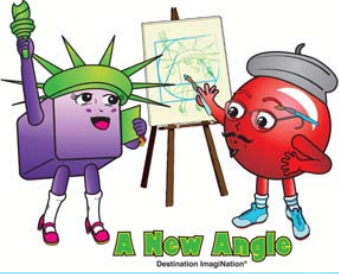

Check-in Room

- **Appraiser will then score:**
 - Workmanship and Uniqueness of Structure Design
- **Team may repeat Check-in to bring structure into compliance**
- **Structure container will be sealed. Team members will carry structures to performance site holding area for safe-keeping (site specific instructions)**
- **Team will be reminded to bring safety goggles for testing if needed**



Challenge - Performance Site

- Each site will be slightly different
- Taped off area indicating safety zone around tester, Non-weight handling performers should **STAY CLEAR** of testing device
- End of extension cord will be provided
- Continuous flow (one team in Prep while another performs)

Team Flow

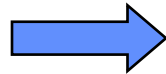

Prep Area



Launch Area

Tester + safety zone

Weight assistant waiting area

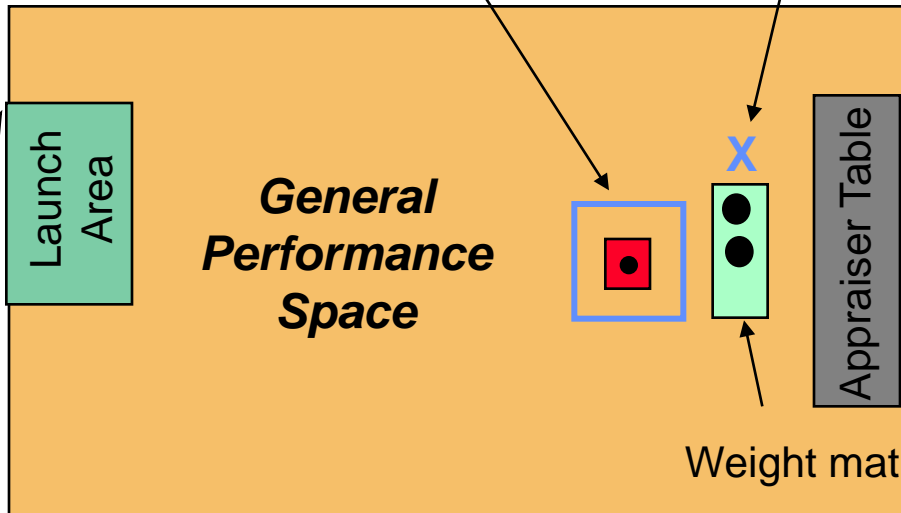

Team Exit



AUDIENCE

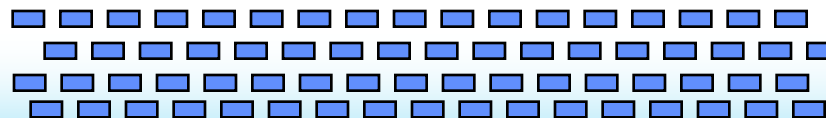

Audience Flow



Challenge - Performance Start

■ Prep Area

- Appraiser will greet team, go through checklist
- Team hands over paperwork
- Go over site, **goggles**, **shoes**

■ Launch Area

- Go over site, weights, procedure for weight assistant
- Team opens structure container
- Team will be introduced (by team)
- Team will be told to begin
- 8 minutes for performance and testing

■ Teams will be allowed full 8 minutes to complete everything

- Timer will not stop if team calls *time* at end, team will be allowed to finish weight placement ,





Simultaneous Testing & Performance

- Setup, performance and weight testing all within 8 minutes
 - Team decides how performance and testing is staged



PERFORMANCE



Overall Scoring

- Official weight held ratio 38%
- Workmanship of structures 7%
- Story (story, art forms...) 15%
- Two Side Trips 15%
- Instant Challenge 25%



Tester setup

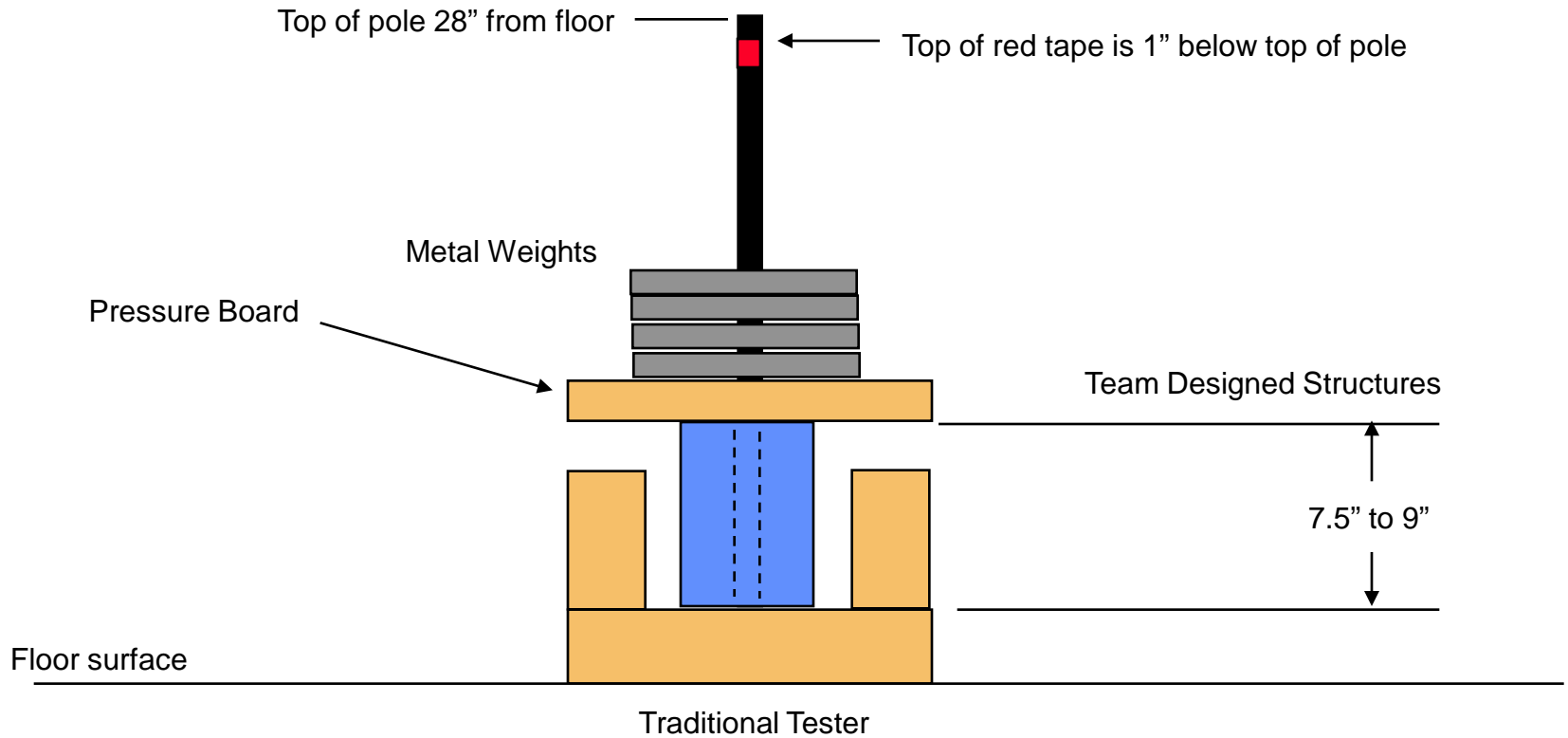



Challenge - Testing

Weight placement rules

- Adult assistant can help: ≥ 25 lbs (Elementary & Intermediate) (however, must be directed by team member & (team member(s) must carry non-trivial share of weight)
- Adult assistant must return to **X-mark** after each weight placement (removal)
- The first weight to be applied is the pressure board (nominally 10 lbs)
- Weight placement ends if pressure board touches any of 4 support posts, weights reach **27"** mark on pole*, 8 minute period ends, team elects to stop

**NOTE: teams can elect to remove weights even if 27" passed, to change weights, but removed weights do not count*

Recommended Weights for Regional tournaments					
wt.	5	10	25	35	45
#	10	10	5	5	5

Pressure Board ~ 10 lbs

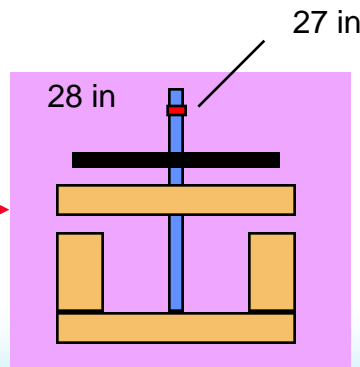



Challenge - Testing

Recommended Weights for Regional tournaments					
wt.	5	10	25	35	45
#	10	10	5	5	5

Pressure Board ~ 10 lbs →

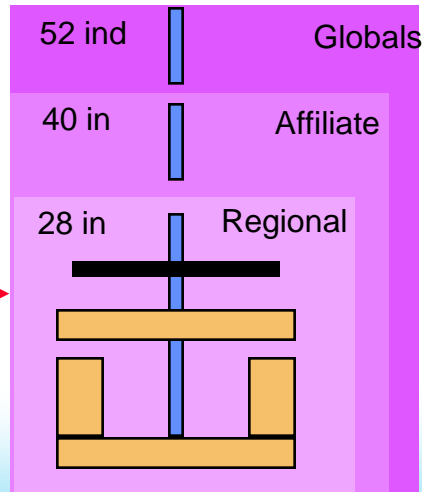



Immediately After Performance

- **Team will receive applause (line up for photo)**
- **Participation pins awarded**
- **APPRAISERS interviews team on aspects of solution**
- **PLEASE: do not allow family/friends to enter performance area until Appraisers signal for help to clear area. Parents and friends can then help to quickly clear and clean the area.**
- **Team representative and/or Team Manager can collect raw score sheet and comments approx. 45 min. after performance**



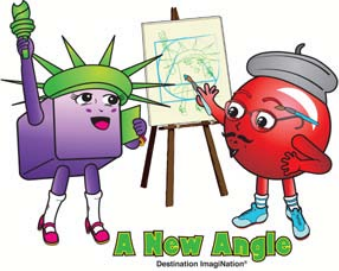

Reminders

- **Anyone can help bring props from cars to building to Prep Area**
- **TMs may assist moving props to Launch**
- **You may point out to team that you broke something**
- **But only team members can repair solution**
- **Anyone can help clear the presentation area after the performance**
- **No one is allowed to plug in anything at the tournament except the team during their scheduled performance**

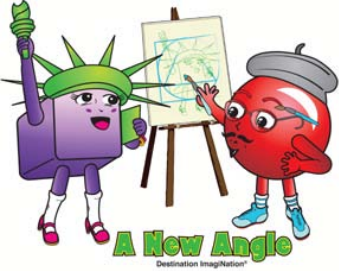

Current Clarifications

- **...It is not interference for responsible adults to audit and limit team members from researching or using characters or situations they deem inappropriate for the team members' ages or circumstances ...**
- **The last sentence of C.2.d should read: To verify the smaller dimension, the team will also place the smaller end of each part of the Structure into a 3.0 inch circle which is resting on a flat surface**



Final Comments

- **Enjoy the excitement of the tournament**
- **Appreciate the diversity of solutions**
- **Appreciate how far teams have come since they first started**
- **Relax and have a fun day!**

