



Breaking DI News



2010 Tournament Procedures



First Thing to Do

- **Go to the “CHECKER” table in morning**
 - Go over forms to make sure you have them all
- **Forms and paperwork**
 - Tournament Data Form (5 copies)
 - Declaration of Independence (2 copies)
 - Expense Report Form (1)
 - Any Team Clarification Forms
 - A copy of newsworthy event in English
- **Team Identification Sign (NOT scored)**
 - Just to let everyone know who you are
- **Get Tournament schedule**
 - Find out Instant Challenge (IC), Check-In, and Performance times and plan accordingly



Check-In Procedure

- **Each team has scheduled Check-in, Perform. & IC times**
- **Usually Check-in will be in morning, Performance in afternoon**
 - Teams will be scheduled in same order as Performances
 - As time permits, teams are encouraged to check in as early as possible
- **Teams will be in Check-in for about 10-15 min.**
 - Weighing and qualifying weight-bearing newspaper and glue structures
 - Discussions with appraisers about building experience
 - Structures will be kept for safe-keeping, told when to pick up for performance (please bring appropriate container)



Check-in Room

- Focus on team members
- Only team members handle structures
- Structure is weighed
 - Total structure weight ≤ 75 grams
- Appraiser will then check:
 - $7 \frac{1}{2}'' \leq$ structure height above tester surface $\leq 9''$
 - Structure accepts a **2** inch column over entire height of structure
 - Structure fits onto tester base and is a single unit
 - Structure made out of **printed newsprint** and commercially available **glue**
 - Only glue is allowed to contact newspaper (not water, alcohol, etc.)





Check-in Room

- **Appraiser will then score:**
 - Structure's creativity and quality of design
- **Team may repeat Check-in to bring structure into compliance**
- **Structure container will be sealed. Team members will carry structures to performance site holding area for safe-keeping (site specific instructions)**
- **Team will be reminded to bring safety goggles for testing if needed**



Challenge - Performance Site

- Each site will be slightly different
- Taped off area indicating safety zone around tester, Non-weight handling performers should **STAY CLEAR** of testing device
- End of extension cord will be provided
- Continuous flow (one team in Prep while another performs)

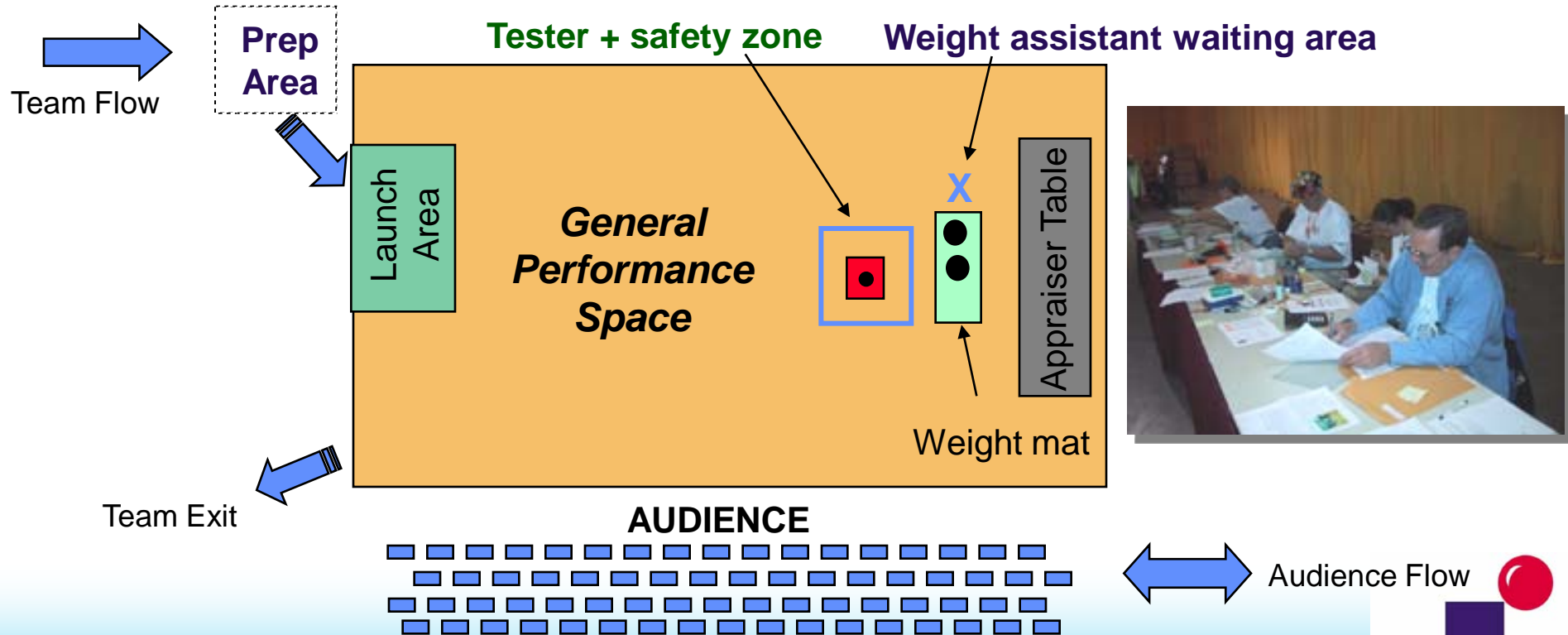



Challenge - Performance Start

- **Prep Area (20 min. before official performance time)**

- Appraiser will greet team, go through checklist
- Appraiser checks closed prop container (30"x24"x48")
- Team gets structure container
- Team hands over paperwork (cost, tournament forms)
- Go over site, **goggles, shoes**



- **Launch Area**

- Go over site, weights, procedure for weight assistant
- Team leaves prop container closed
- Team will be introduced (by team)
- Team will be told to begin
- 8 minutes for performance and testing

- **Teams will be allowed full 8 minutes to complete everything**

- Timer will not stop if team calls *time* at end, team will be allowed to finish weight placement ,





Simultaneous Testing & Performance

- Setup, performance and weight testing all within **8 minutes**
 - Team decides how performance and testing is staged



PERFORMANCE

PRO



Tester setup

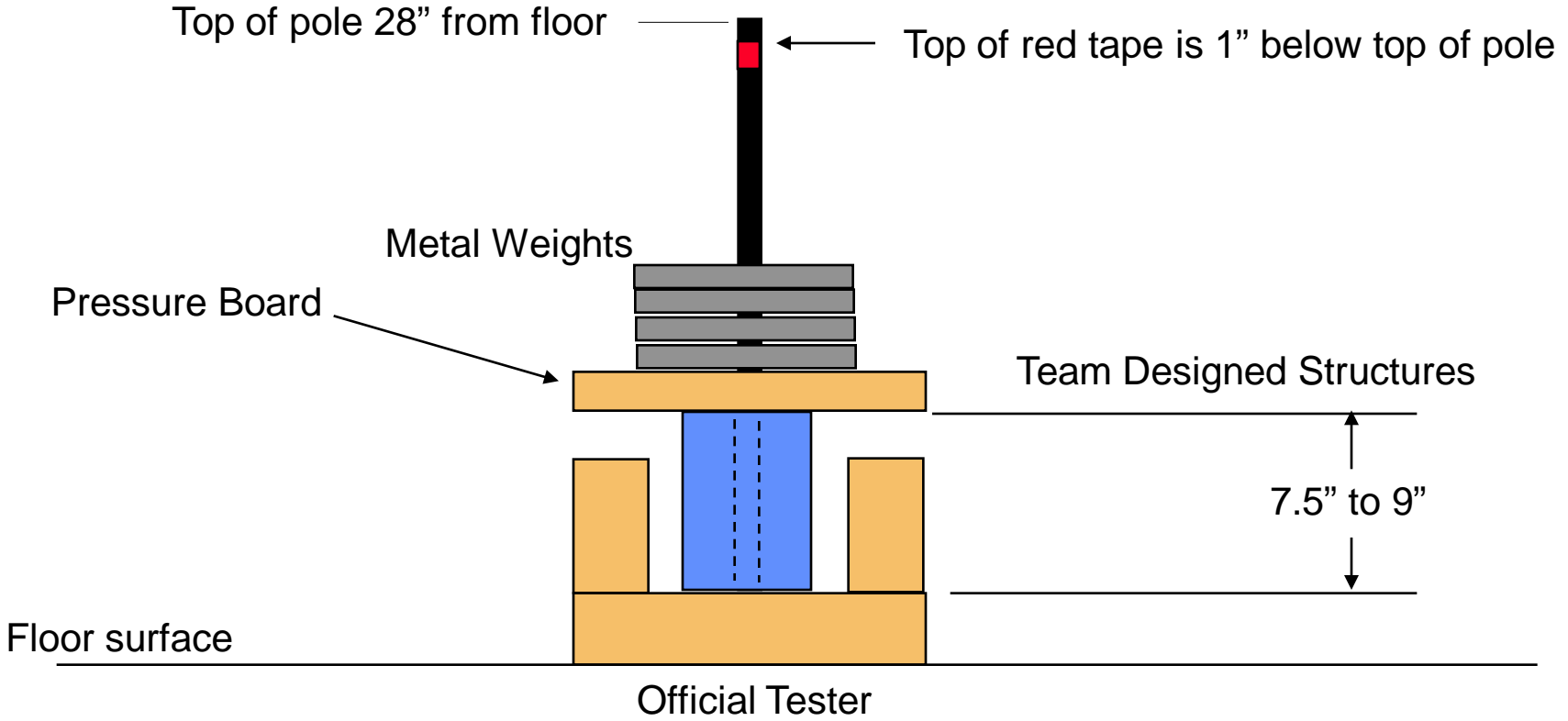



Challenge - Testing

Weight placement rules

- Adult assistant can help: ≥ 25 lbs (Elementary & Intermediate) (however, must be directed by team member & (team member(s) must carry non-trivial share of weight)
- Adult assistant must return to **X-mark** after each weight placement (removal)
- The first weight to be applied is the pressure board (nominally 10 lbs)
- Pressure board and weights can touch pole (change from last year)
- Weight placement ends if pressure board touches any of 4 support posts, weights reach **27"** mark on pole*, 8 minute period ends, team elects to stop

**NOTE: teams can elect to remove weights even if 27" passed, to change weights, but removed weights do not count*

| Recommended Weights for Regional tournaments | | | | | |
|--|----------|-----------|-----------|-----------|-----------|
| wt. | 5 | 10 | 25 | 35 | 45 |
| # | 10 | 10 | 5 | 5 | 5 |

Pressure Board ~ 10 lbs

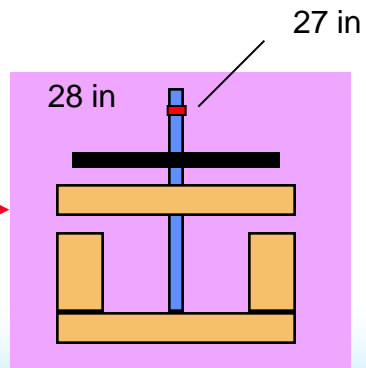



Challenge - Testing

| Recommended Weights for Regional tournaments | | | | | |
|--|----------|-----------|-----------|-----------|-----------|
| wt. | 5 | 10 | 25 | 35 | 45 |
| # | 10 | 10 | 5 | 5 | 5 |

Pressure Board ~ 10 lbs →

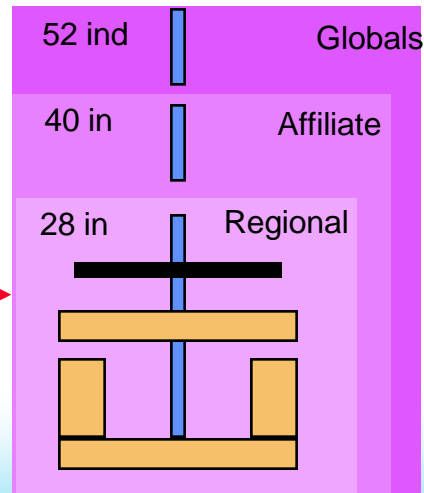



Immediately After Performance

- Team will receive applause (line up for photo)
- Participation pins awarded
- **APPRAISERS** interviews team on aspects of solution
- **PLEASE:** do not allow family/friends to enter performance area until Appraisers signal for help to clear area. Parents and friends can then help to quickly clear and clean the area.
- Team representative and/or Team Manager can collect raw score sheet and comments approx. 45 min. after performance





Structure Scoring

- Weight Held Ratio
 - Weight Held (in lbs) divided by Weight of Structure (in grams)
- Structure creativity and quality of design



Overall Scoring

- Official weight held 37.5%
- Structure creativity and design 5%
- Story 17.5%
- Two Side Trips 15%
- Instant Challenge 25%



Review of Story Elements

- Creativity of presentation of a Story about a Newsworthy event in a nation other than your own
- Provide a copy of the Newsworthy Event article in English
- Provide a container with rigid sides (no more than 30"x24"x48") that fully encloses all props & scenery except for the Structure, Structure container and team identification sign
- The creativity of the container
- The creative use of newsprint in a costume or prop
- Two Side Trips

NOTE: Cost of all items on stage \leq **\$50**
(see Rules of Road for excluded items)



Reminders

- **Anyone can help bring props from cars to building to Prep Area**
- **TMs may assist moving props to Launch**
- **You may point out to team that you broke something**
- **But only team members can repair solution**
- **Anyone can help clear the presentation area after the performance**
- **No one is allowed to plug in anything at the tournament except the team during their scheduled performance**



Current Clarifications

- **Oct 8:** After the container has been checked in the Prep Area, the team will move it, unopened, to the Launch Area. After the 8-min Presentation time begins, the team may open and unpack the container
- **Dec 22:** Your team may not apply anything other than commercially available Glue to the newsprint. Glue may be used to join pieces of paper or as a coating. Teams may not produce their own “homemade” Glues. The addition of water to a commercially available Glue will not be considered a “homemade” Glue. Teams should be prepared to supply the container for the Glue they used to build the structure.



Final Comments

- **Enjoy the excitement of the tournament**
- **Appreciate the diversity of solutions**
- **Appreciate how far teams have come since they first started**
- **Relax and have a fun day!**

